

Fresa circular, corte 3 lados.
Side milling cutter, cutting on 3 sides.

DENTE
RETO

M2

DIN
885 BH



1202

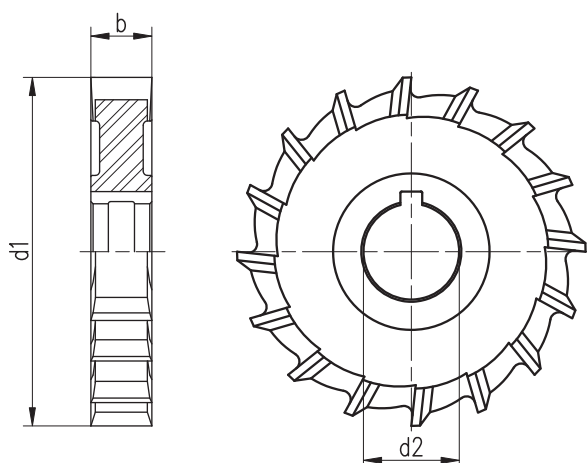

d1 js 16 mm	b k 11 mm	d2 H7 mm	Z
50	4	16	14
50	5	16	14
50	6	16	14
50	8	16	14
50	10	16	14
63	4	22	16
63	5	22	16
63	6	22	16
63	8	22	16
63	10	22	16
63	12	22	16
63	14	22	16
63	16	22	16
63	18	22	16
80	5	27	18
80	6	27	18
80	8	27	18
80	10	27	18
80	12	27	18
80	14	27	18
80	16	27	18
80	18	27	18
80	20	27	18
100	6	32	20
100	8	32	20
100	10	32	20
100	12	32	20
100	14	32	20
100	16	32	20
100	18	32	20
100	20	32	20
100	22	32	20
100	25	32	20
125	6	32	22
125	8	32	22
125	10	32	22
125	12	32	22
125	14	32	22
125	16	32	22
125	18	32	22
125	20	32	22
125	22	32	22
125	25	32	22
125	28	32	22

d1 js 16 mm	b k 11 mm	d2 H7 mm	Z
150	6	32	24
150	8	32	24
150	10	32	24
150	12	32	24
150	14	32	24
150	16	32	24
150	18	32	24
150	20	32	24
150	22	32	24
150	24	32	24
150	26	32	24
150	28	32	24
160	8	40	24
160	10	40	24
160	12	40	24
160	14	40	24
160	16	40	24
160	18	40	24
160	20	40	24
160	22	40	24
160	25	40	24
160	28	40	24
160	32	40	24
200	8	40	28
200	10	40	28
200	12	40	28
200	14	40	28
200	16	40	28
200	18	40	28
200	20	40	28
200	22	40	28
200	25	40	28
200	28	40	28
200	32	40	28
200	36	40	28
200	40	40	28
250	10	40	34
250	12	40	34
250	14	40	34
250	16	40	34
250	18	40	34
250	20	40	34
250	25	40	34
250	28	40	34
250	32	40	34

Dados de corte, ver página 127

Fresa circular, corte 3 lados.
Side milling cutter, cutting on 3 sides.

DENTE RETO
M2
DIN 885 BH

1202

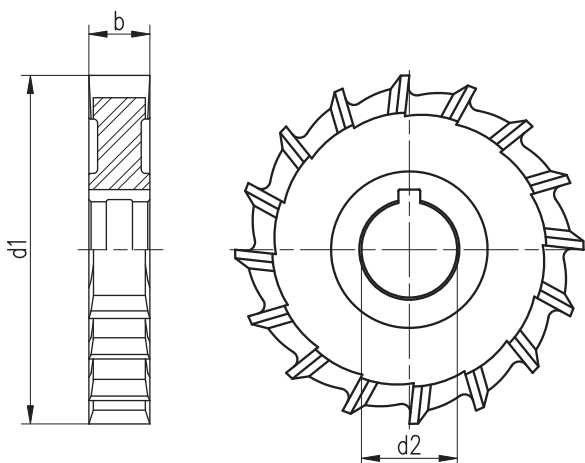

d1 js 16 pol	b k 11 pol	d2 H7 pol	Z
2	1/8	5/8	14
2	3/16	5/8	14
2	1/4	5/8	14
2	5/16	5/8	14
2	3/8	5/8	14
2 1/2	3/16	7/8	16
2 1/2	1/4	7/8	16
2 1/2	5/16	7/8	16
2 1/2	3/8	7/8	16
2 1/2	7/16	7/8	16
2 1/2	1/2	7/8	16
3	3/16	1	18
3	1/4	1	18
3	5/16	1	18
3	3/8	1	18
3	7/16	1	18
3	1/2	1	18
3	9/16	1	18
3	5/8	1	18
3	3/4	1	18
3 1/2	3/16	1	18
3 1/2	1/4	1	18
3 1/2	5/16	1	18
3 1/2	3/8	1	18
3 1/2	1/2	1	18
3 1/2	5/8	1	18
3 1/2	3/4	1	18
4	3/16	1 1/4	20
4	1/4	1 1/4	20
4	5/16	1 1/4	20
4	3/8	1 1/4	20
4	7/16	1 1/4	20
4	1/2	1 1/4	20
4	9/16	1 1/4	20
4	5/8	1 1/4	20
4	3/4	1 1/4	20
4	7/8	1 1/4	20
4	1	1 1/4	20

d1 js 16 pol	b k 11 pol	d2 H7 pol	Z
5	3/16	1 1/4	22
5	1/4	1 1/4	22
5	5/16	1 1/4	22
5	3/8	1 1/4	22
5	7/16	1 1/4	22
5	1/2	1 1/4	22
5	5/8	1 1/4	22
5	3/4	1 1/4	22
5	7/8	1 1/4	22
5	1	1 1/4	22
6	3/16	1 1/4	24
6	1/4	1 1/4	24
6	5/16	1 1/4	24
6	3/8	1 1/4	24
6	7/16	1 1/4	24
6	1/2	1 1/4	24
6	5/8	1 1/4	24
6	3/4	1 1/4	24
6	7/8	1 1/4	24
6	1	1 1/4	24
6	1 1/4	1 1/4	24
8	3/8	1 1/2	28
8	7/16	1 1/2	28
8	1/2	1 1/2	28
8	5/8	1 1/2	28
8	3/4	1 1/2	28
8	7/8	1 1/2	28
8	1	1 1/2	28
8	1 1/4	1 1/2	28

Dados de corte, ver página 127